

270526-TC

Grounding and Bonding for Telecommunications Systems

Part 1 - General

1.1 Work Included

- A. Provide all labor, materials, tools and equipment required for the complete installation of work called for in the Construction Documents

1.2 Scope of Work

- A. This document describes the products and execution requirements relating to furnishing and installing Grounding/Earthing and Bonding for Communications Systems.
- B. This section includes minimum requirements for the following:
 - • Grounding/Earthing System
 - • Telecommunications Grounding Busbar (TGB)
 - • Telecommunications Main Grounding Busbar (TMGB)
 - • Telecommunications Bonding Backbone (TBB)
 - • Rack Grounding/Earthing and Bonding
- C. All cables and related terminations, support and grounding/earthing hardware shall be furnished, installed, wired, tested, labeled, and documented by the telecommunications contractor as detailed in this document.
- D. Product specifications, general design considerations, and installation guidelines are provided in this document. Quantities grounding/earthing products, typical installation details and cable routing will be provided as an attachment to this document. If the bid documents are in conflict, this specification shall take precedence. The successful vendor shall meet or exceed all requirements for the cable system described in this document.

1.3 Regulatory References

- A. The following industry standards are the basis for the grounding/earthing and bonding system described in this document.

TIA/EIA

TIA-942	Telecommunications Infrastructure Standard for Data Centers
J-STD-607-A	Commercial Building Grounding/Bonding Requirements
TIA/EIA-606	Administration Standard for the Telecommunications Infrastructure of Commercial Buildings
<u>IEEE</u>	
Std 1100	IEEE Recommend Practice for Powering and Grounding Electronic Equipment (IEEE Emerald Book)
<u>NFPA</u>	
NFPA-70	National Electric Code (NEC)

- B. The most recent versions of all documents apply to this project. If there is a conflict between applicable documents, the order above shall dictate the order of precedence in resolving the issue unless an enforceable local or national code is in effect.

1.4 Quality Assurance

1.5 Definitions

Bonding – The permanent joining of metallic parts to form an electrically conductive path that will assure electrical continuity and the capacity to conduct safely any current likely to be imposed.

Common Bonding Network (CBN) – The principal means for affecting bonding and earthing inside a building.

Ground/Earth – A conducting connection, whether intentional or incidental, by which an electric circuit or equipment is connected to earth, or to some conducting body of relatively large extent that serves in place of the earth.

Retrofit Rack Grounding/Earthing – The application of grounding/earthing products and technology where equipment is already deployed and functioning.

1.6 Overview

The purpose of the grounding/earthing system is to create a low impedance path to earth ground for electrical surges and transient voltages. Lightning, fault currents, circuit switching (motors turning on and off), and electrostatic discharge are common causes of these surges and transient voltages. An effective grounding/earthing system minimizes the detrimental effects of these

electrical surges, which include degraded network performance and reliability and increased safety risks.

The grounding/earthing system must be intentional, visually verifiable, adequately sized to handle expected currents safely, and directs these potentially damaging currents away from sensitive network equipment. As such, grounding/earthing must be purposeful in its design and installation. Four issues require special consideration:

Although AC powered equipment typically has a power cord that contains a ground/earth wire, the integrity of this path cannot be easily verified. Thus, many equipment manufacturers require grounding/earthing above and beyond that which is specified by local electrical codes, such as the National Electrical Code, etcetera. Always follow the grounding/earthing recommendations of the manufacturer when installing equipment.

While the building steel and metallic water piping must be bonded to the grounding/earthing system for safety reasons, neither may be substituted for the telecommunications bonding backbone (TBB).

Electrical continuity throughout each rack or cabinet is required to minimize safety risks. Hardware typically supplied with bolt-together racks is not designed for grounding/earthing purposes. Additionally, most racks are painted. Paint is an insulator. Unless rack members are deliberately bonded, continuity between members is incidental, and in many cases, unlikely.

Any metallic component that is part of the data center, including equipment, racks, ladder racks, enclosures, cable trays, etc. must be bonded to the grounding/earthing system with a 1 ohm resistance between 2 point.

1.7 Workmanship

The ground/earth system must be designed for high reliability. Therefore, the grounding/earthing system shall meet following criteria:

Local electrical codes shall be adhered to.

The grounding/earthing system shall comply with ANSI/TIA-942 and J-STD-607-A.

All grounding/earthing conductors shall be copper.

Lugs, HTAPs, grounding strips, and busbars shall be UL Listed and made of premium quality tin-plated electrolytic copper that provides low electrical resistance while inhibiting corrosion. Antioxidant shall be used when making bonding connections in the field.

Wherever possible, two-hole lugs shall be used because they resist loosening when twisted (bumped) or exposed to vibration. All lugs shall be irreversible compression and meet NEBS Level 3 as tested by Telcordia. Lugs with inspection windows shall be used in all non-corrosive environments so that connections may be inspected for full conductor insertion (battery rooms are an exception where windowless lugs may be used).

Die index numbers shall be embossed on all compression connections to allow crimp inspection.

Cable assemblies shall be UL Listed and CSA Certified. Cables shall be a distinctive green or green/yellow in color, and all jackets shall be UL, VW-1 flame rated.

Part 2 - Products

2.1 Grounding/Earthing and Bonding

The Telecommunications Grounding Busbar (TGB) in each telecommunications space will be grounded/earthed to the Telecommunications Main Grounding Busbar (TMGB) located at the service entrance. The gauge of the connecting ground/earth cable, known as the Telecommunications Bonding Backbone (TBB) will follow J-STD-607-A guidelines, as is shown in the table below.

Sizing of the TBB	
TBB Length in Linear meters (feet)	TBB Size (AWG)
Less than 4 (13)	6
4-6 (14-20)	4
6-8 (21-26)	3
8-10 (27-33)	2
10-13 (34-41)	1
13-16 (42-52)	1/0
16-20 (53-66)	2/0
Greater than 20 (66)	3/0

The TMGB will be bonded to building steel and grounded/earthed to the electrical service ground according to BICSI TDM Manual and J-STD-607-A guidelines. Local codes may supersede these requirements. In telecommunications spaces with only one rack, the rack jumper cable can be connected directly to the TGB.

1.01

Cable Sizes for Other Grounding/Earthing Applications	
Purpose	Copper Code Cable Size
Aisle grounds (overhead or under floor) of the common bonding network	#2 AWG or larger (1/0 preferred)
Bonding conductor to each PDU or panel board serving the room.	Size per NEC 250.122 & manufacturer recommendations
Bonding conductor to HVAC equipment	6 AWG
Building columns	4 AWG
Cable ladders and trays	6 AWG
Conduit, water pipe, duct	6 AWG

2.2 Components, Kits and Hardware

STRUCTUREDGROUND[™] Grounding System (*STRUCTUREDEARTH*[™] Earthing System) kits, components, and hardware shall be used to construct the grounding/earthing system.

Use lugs when connecting conductors to the TMGB and TGB.

Route the TBB to each TGB in as straight a path as possible. The TBB should be installed as a continuous conductor, avoiding splices where possible. Use HTAP kits to provide a tap from the TBB to each TGB. When more than one TBB is used, bond them together using the TGBs on the top floor and every third floor in between with a conductor known as a Grounding Equalizer (GE). Use the J-STD-607-A guidelines for sizing of the TBB when sizing the GE (shown in the table above).

Avoid routing grounding/earthing conductors in metal conduits. If the grounding/earthing conductor must be routed through a metal conduit, bond each end of the conduit to the grounding/earthing conductor. Use grounding clamps to bond to the conduit, and a #6 AWG copper conductor to connect the GPL grounding clamp to the HTWC HTAP.

2.3 Rack Grounding/Earthing

Equipment and racks shall be bonded in accordance with the methods prescribed in ANSI/TIA-942, as is shown in the figure below.

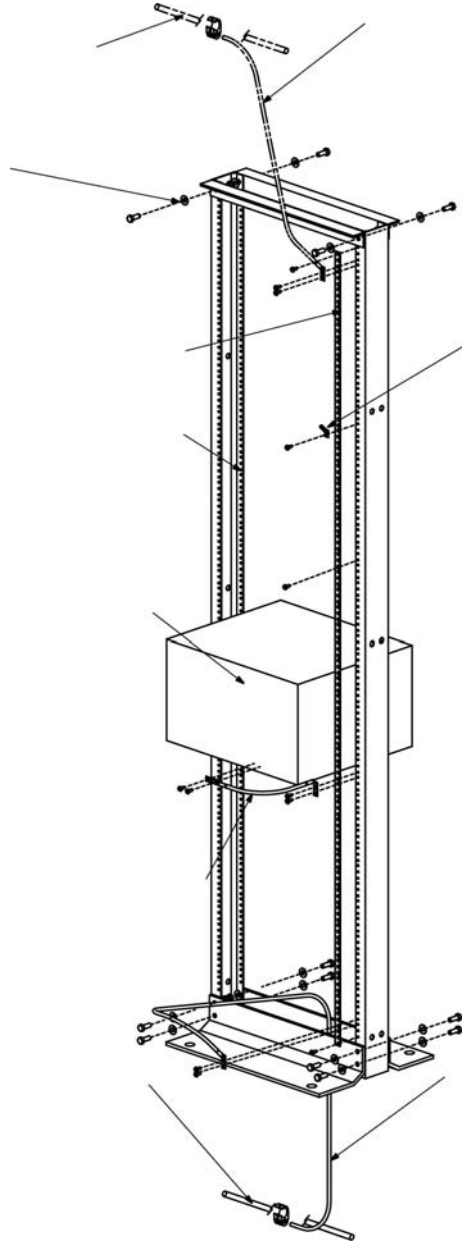

Figure 1 - Properly Grounded/Earthed Rack (Back of Rack Shown)

To provide electrical continuity between rack elements, paint piercing grounding washers, shall be used where rack sections bolt together, on both sides, under the head of the bolt and between the nut and rack.

When the equipment manufacturer provides a location for mounting a grounding connection, that connection shall be utilized. Use the appropriate jumper for the equipment being installed and the thread-forming screws provided in the kit.

Do not bond racks or cabinets serially. Use the copper compression HTAP that comes with the kit to bond the conductor to the common bonding network.

2.4 Retrofit Rack Grounding/Earthing

If the racks already have network equipment installed, it may not be feasible to install the rack ground strip without disrupting data cables. Further, it may be undesirable to disassemble rack hardware to install paint piercing grounding washers

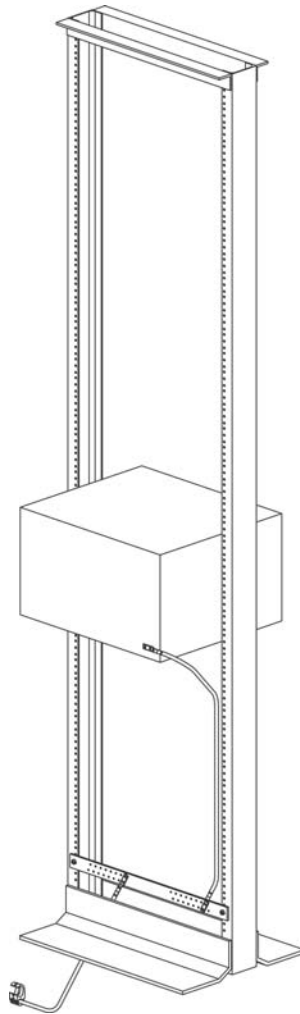

Figure 2 - Retrofit Rack Grounding/Earthing

RGW paint piercing grounding washers are not used in this scenario. Thus, the grounding busbar provides continuity through the vertical channels of the rack, but not the top and bottom of the rack. Thus, wherever practical, the solution using the RGS rack grounding strip and the RGW paint piercing washers shall be used instead of the retrofit rack grounding kits.

All other grounding/earthing requirements apply to retrofit installations without exception.

Part 3 - Execution

3.1 Grounding System

The communications grounding system shall be designed and/or approved by a qualified PE, licensed in the state that the work is to be performed. The communications grounding system shall adhere to the recommendations of the ANSI/TIA-942 and J-STD-607-A standards, and shall be installed in accordance with best industry practice.

A licensed electrical contractor shall perform installation and termination of the main bonding conductor to the building service entrance ground.